

PART NAME	PLASTICASE (STYLE A)	PART No.	PC-11403
-----------	----------------------	----------	----------

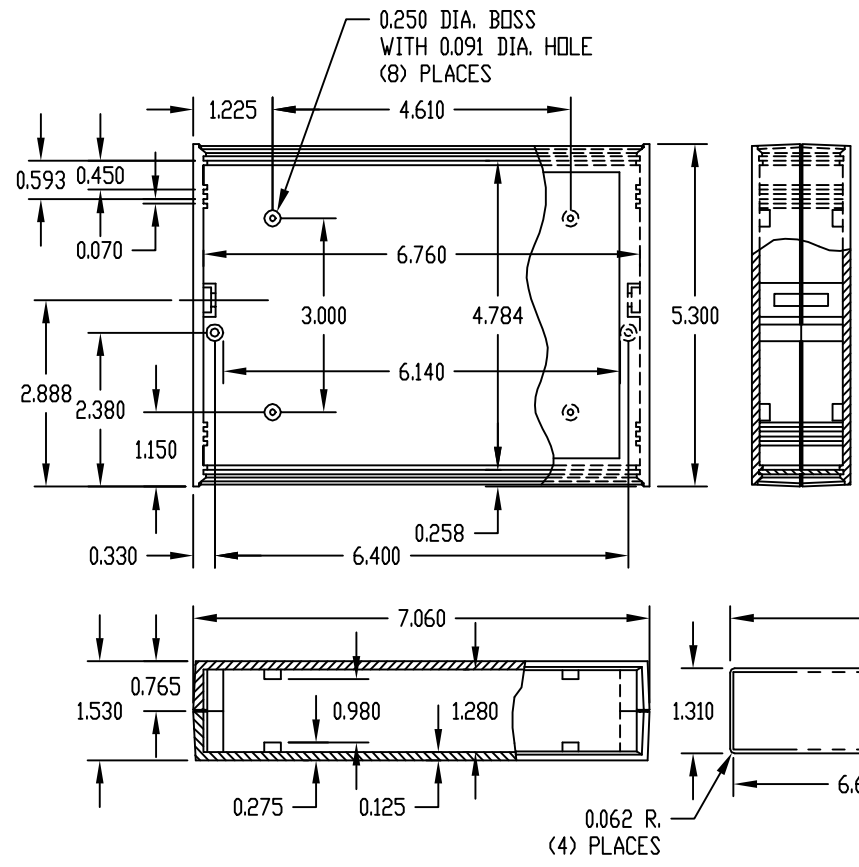

MATERIAL: HIGH-IMPACT POLYSTYRENE
 FINISH: DOUBLE-TEXTURED
 PC BONE GRAY
 TWO (2) #4 x 1.000" LG. SCREWS
 & FOUR (4) RUBBER FEET
 SUPPLIED WITH CASE FOR
 ASSEMBLY.
 NOTE: MOUNTING BOSSES USE
 EITHER M2.5 METRIC OR #4
 STD. SHEET METAL SCREWS
 x 0.250" LG. (NOT SUPPLIED)
 ALL DIMENSIONS HAVE ±0.015 TOLERANCE
 UNLESS OTHERWISE SPECIFIED

PART NAME	POTTING BOX (STYLE A)	PART No.	PB-1558 & PB-1559 / PB-1574 TO PB-1583
-----------	-----------------------	----------	--

MATERIAL: ABS THERMOPLASTIC (FLAMMABILITY RATING OF 94-V0 AT
 0.070" THICKNESS AND CONTINUOUS USE
 TEMPERATURE OF 70° C.)

COLOR: BLACK

FINISH: OUTSIDE SURFACES ARE TEXTURED FINISH.

COVER REDUCES INSIDE HEIGHT BY 0.075,
 EXCEPT ON PB-1577 COVER REDUCES
 INSIDE HEIGHT BY 0.060 & PB-1583 COVER
 REDUCES INSIDE HEIGHT BY 0.110.

ALL COVERS HAVE SMOOTH SURFACES.

LENGTH AND WIDTH DIMENSIONS ARE TAKEN
 FROM CLOSED END OF THE BOX. DIMENSIONS
 INCREASE SLIGHTLY AT OPEN END DUE TO TAPER.

ALL DIMENSIONS HAVE ±0.010 TOLERANCE
 UNLESS OTHERWISE SPECIFIED

SHIPPED IN PACKAGES OF TEN (10).

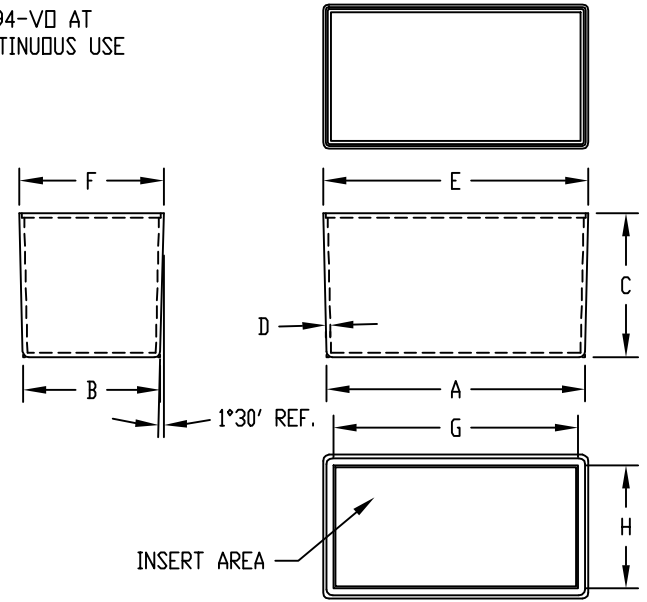

PART No.	A	B	C	D	E	F	G	H	OPTIONAL COVER
PB-1558	2.000	1.500	1.000	0.070	2.052	1.552	-----	-----	PBC-1558-CN
PB-1559	3.000	2.000	1.500	0.070	3.078	2.078	-----	-----	PBC-1575-C
PB-1574	2.000	2.000	1.500	0.070	2.078	2.078	-----	-----	PBC-1574-C
PB-1575	3.030	2.030	0.900	0.070	3.078	2.078	-----	-----	PBC-1575-C
PB-1576	3.000	3.000	1.500	0.070	3.078	3.078	-----	-----	PBC-1576-C
PB-1577	1.030	1.030	0.780	0.060	1.072	1.072	-----	-----	PBC-1577-C
PB-1578	4.000	2.125	2.230	0.070	4.105	2.230	3.790	1.906	PBC-1578-C
PB-1579	1.500	1.250	0.800	0.070	1.542	1.292	-----	-----	PBC-1579-C
PB-1580	4.000	1.750	1.000	0.070	4.052	1.802	-----	-----	PBC-1580-C
PB-1581	2.079	1.280	0.445	0.070	2.097	1.300	-----	-----	PBC-1581-C
PB-1582	4.063	2.188	0.900	0.070	4.105	2.230	-----	-----	PBC-1578-C
PB-1583	4.375	3.125	2.000	0.100	4.473	3.223	3.974	2.723	PBC-1583-C